

LCR-819/817

High Precision LCR Meter 12Hz~100kHz/10kHz

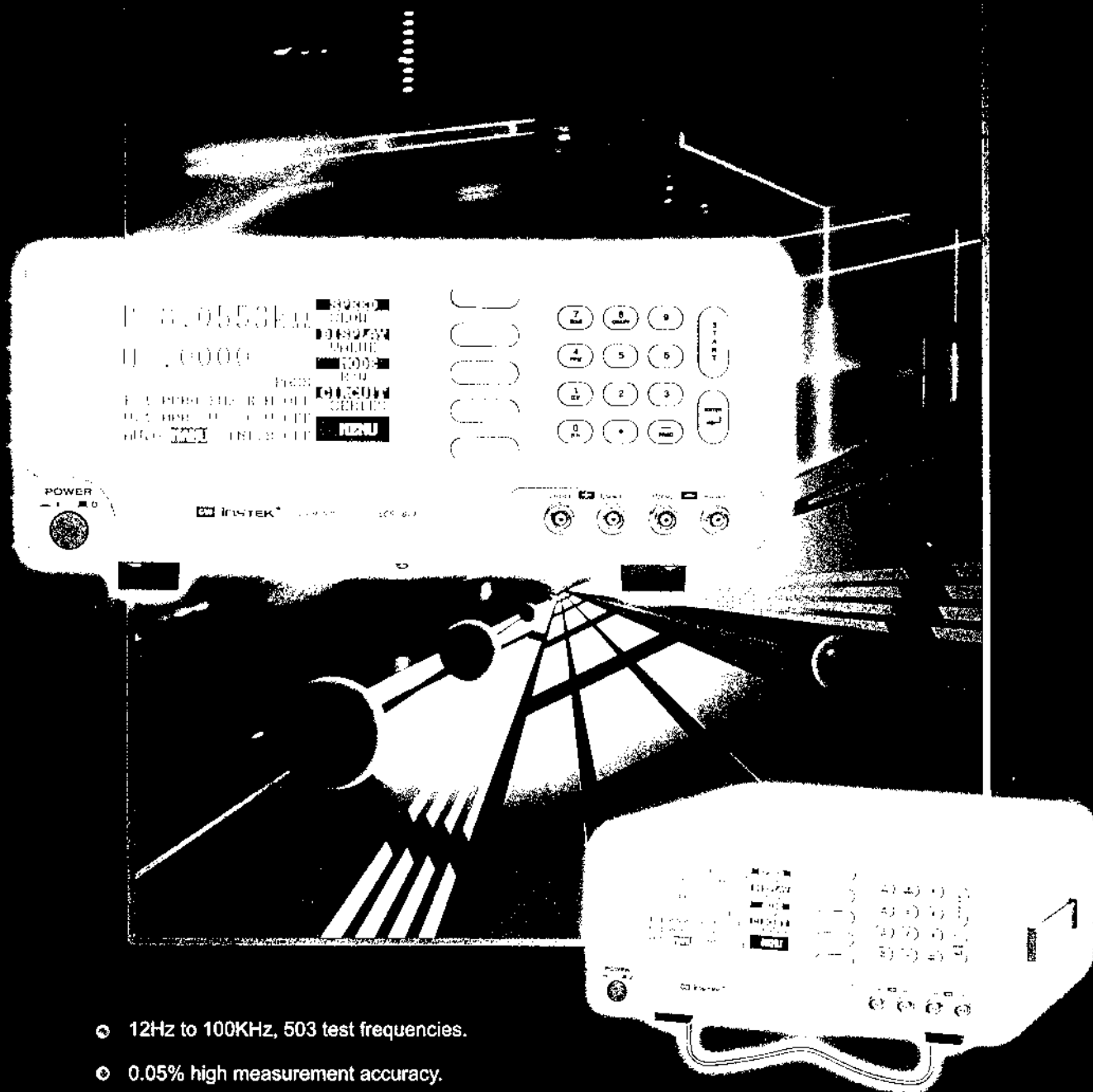

- ⦿ 12Hz to 100KHz, 503 test frequencies.
- ⦿ 0.05% high measurement accuracy.
- ⦿ 100 sets memory for store recall of setup state.
- ⦿ 240 x 128 dot matrix LCD display.
- ⦿ R/Q, C/D, C/R, L/Q test modes.



INSTEK®

LCR-8

12Hz~100KHz/10KHz H

- ↪ 12Hz to 100KHz, 503 continuously variable frequencies.
- ↪ 0.05% high measurement accuracy.
- ↪ 100 sets memory for store/recall of setup state.
- ↪ R/Q, C/D, C/R, L/Q test modes.
- ↪ Absolute value, Δ value, and Δ % measurement display.
- ↪ 240 x 128 dot matrix LCD display.
- ↪ Test condition and test result shown on the screen simultaneously.
- ↪ 5mV to 1.275V test voltage in 5mV/step.
- ↪ 2 V DC internal bias , 30V DC maximum external bias.

NEW
CE

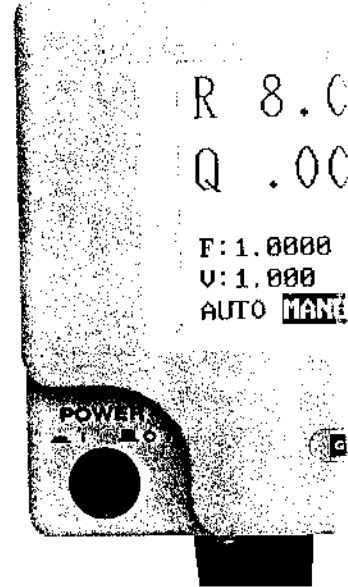

High accuracy and actual operation condition simulation:

The LCR-819/817 LCR Meter is an instrument with high measurement accuracy of 0.05%. It is most useful in the application areas that need both high stability and high accuracy test criteria. The wide coverage of measurement frequency from 12Hz to 100KHz (10KHz for LCR-817) provides versatile parameter-to-frequency measurements to the device under test. The variable test signal voltage from 5mV to 1.275V and the internal/external DC bias selection of LCR-819/817 simulate the real operation condition of DUT and give user a test result of confidence.

LCD Display and 100 sets of memory:

With 240 x 128 high resolution LCD display to show both the test condition and the test result simultaneously, the keypads for menu programming, and the 100 sets of memory to store/recall setup state, LCR-819/817 combines all the user-friendly features in one product.

Test fixtures for various types of components:

Optional fixtures are available for easy measurement of radial leaded, axial leaded, and surface-mounting devices. LCR-819/817 provides you with a solution of accuracy and convenience. With this product, you are confident that component characteristics are shown just as what they really are in the actual operation environment.

TEST FREQUENCY

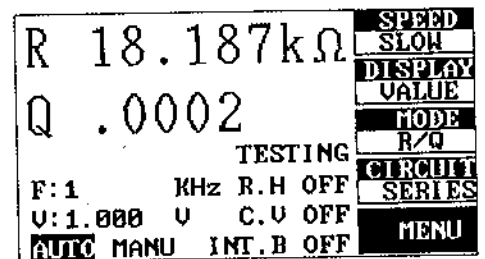

User can setup the "test frequency" on the main screen quickly and easily.

TEST RESULT

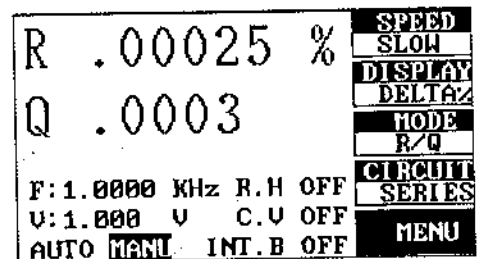

Three modes of measurement display, "VALUE", "DELTA%" and "DELTA", are available for selection depend on the demand.

9/817

h precision LCR Meter

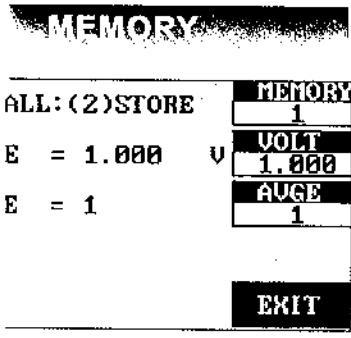
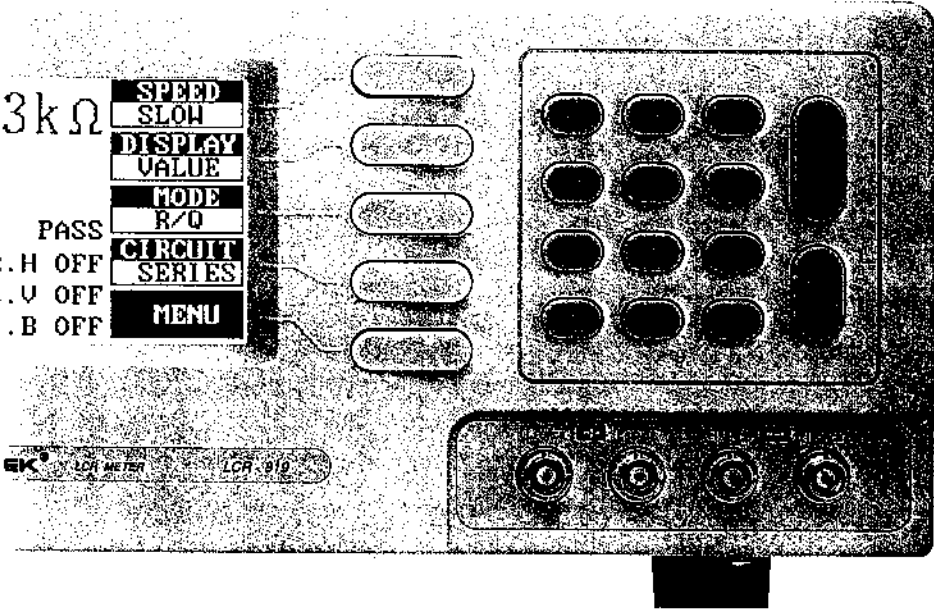

y blocks for setup state store and

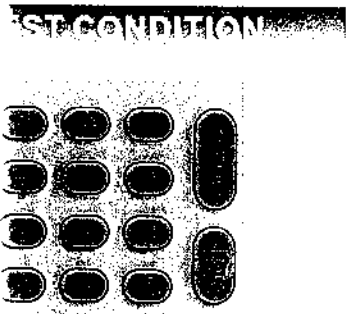

ring, users are able to change the
ent conditions arbitrarily.

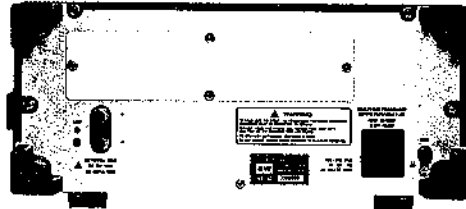

REAR PANEL VIEW

MODEL: LCR-09

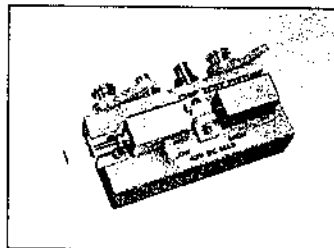

SMD/chip test fixtures

MODEL: LCR-05

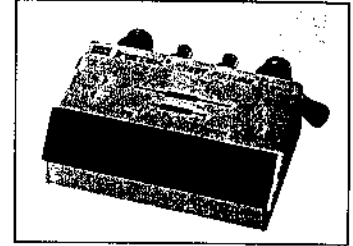

Test fixture for measurement of both axial and vertical lead components.

MODEL: LCR-06

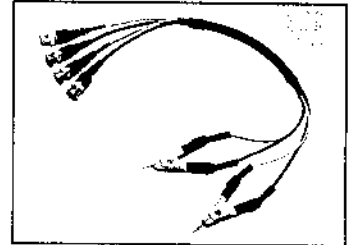

Kelvin clip test leads.

MODEL: LCR-07

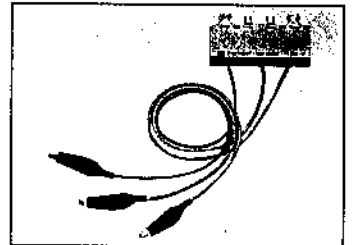

Test leads for conventional component measurement. It is especially useful for high impedance measurement. (with alligator clips)

MODEL: LCR-08

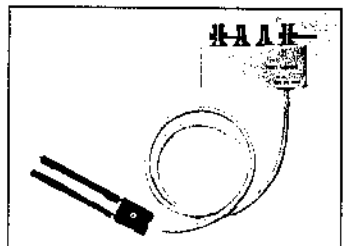

SMD/chip tweezers

LCR-819/817 SPECIFICATIONS

| | LCR-819 | LCR-817 |
|---------------------------|---|---------------------------|
| TEST FREQUENCY | 12Hz to 100kHz (503 steps) | 12Hz to 10kHz (489 steps) |
| BASIC ACCURACY | 0.05% basic accuracy | 0.05% basic accuracy |
| TEST SIGNAL LEVELS | 5mV~1.275mV (5mV/step) | |
| DC BIAS | | |
| Internal | 2V | |
| External | 0 to 30V | |
| DISPLAY RANGE | | |
| Impedance/Resistance R | 0.00000Ω ~ 99999KΩ | |
| Capacitance C | 0.00000pF ~ 99999μF | |
| Inductance L | 0.00000mH ~ 99999H | |
| Quality factor Q | 0.0000 ~ 9999 | |
| Dissipation Factor D | 0.0000 ~ 9999 | |
| TEST MODE | R/Q, C/D, C/R, L/Q | |
| EQUIVALENT CIRCUIT | Parallel or serial selectable | |
| MEMORY | 100 memory blocks totally | |
| AVERAGE | 1 to 255 times | |
| TEST SPEED | SLOW, MEDIUM and FAST | |
| DISPLAY MODE | Value, Δ%, Δ | |
| AC POWER SOURCE | 100V to 240V | |
| LINE FREQUENCY | 50Hz to 60Hz | |
| OPERATING TEMPERATURE | 10° C to 50° C | |
| STORAGE TEMPERATURE | -20° C to 60° C | |
| DISPLAY | 240 x 128 dot matrix C.C.F.L back light LCD | |
| DIMENSIONS | 330 mm (W) x 149mm (H) x 437mm (D) | |
| WEIGHT | 5.5Kg | |

ISO-9001 CERTIFIED MANUFACTURER



GOOD WILL INSTRUMENT CO., LTD.

No. 95-11, Pao-Chung Road, Hsin-Tien City,
Taipei Hsien, Taiwan, R.O.C.

TEL: 886-2-29179188 FAX: 886-2-29179189

URL: <http://www.goodwill.com.tw>

E-mail: marketing@goodwill.com.tw

U.S.A. Office Tel: 1-626-3366537 Fax: 1-626-3691748

Ordering Information :

LCR - 819 12Hz to 100kHz LCR Meter

LCR - 817 12Hz to 100kHz LCR Meter

Specifications subject to change without notice.

CR-819SGD0

線 路 圖

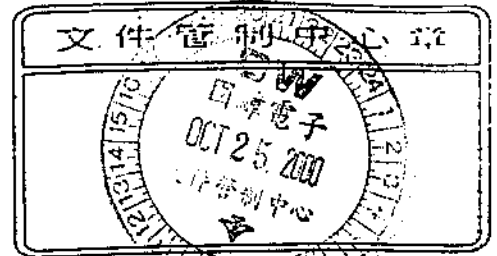

適用機種: LCR-817/819

總頁數 共 6 頁

| 版本 | 發行 / 變更說明 | ECR NO. | 修訂日期 |
|----|-----------|--------------|----------|
| ○ | 初版發行 | — | 88.11.18 |
| | | | |

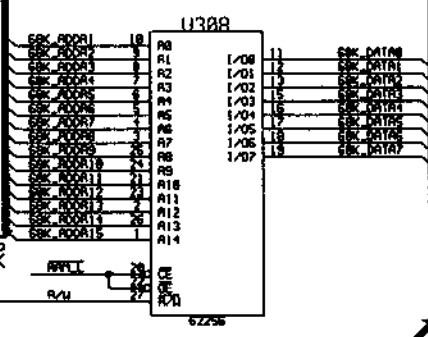
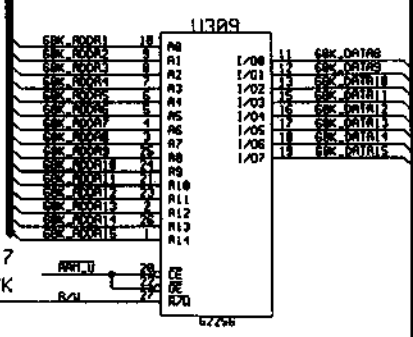
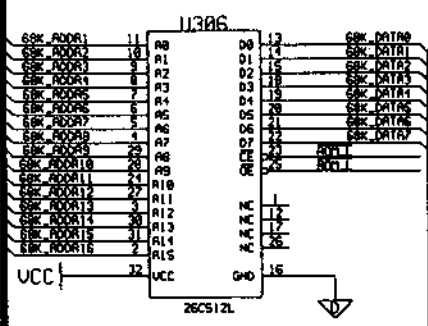
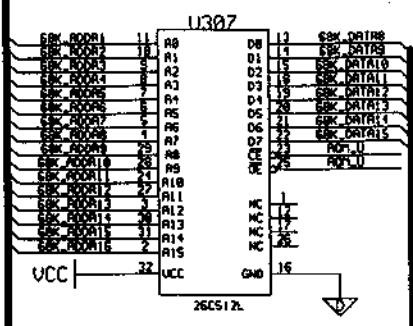
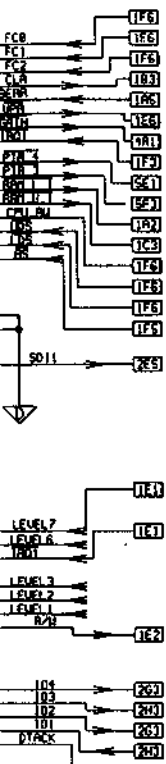

DIR=1, A TO B
DIR=0, B TO A

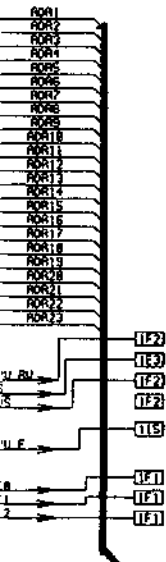
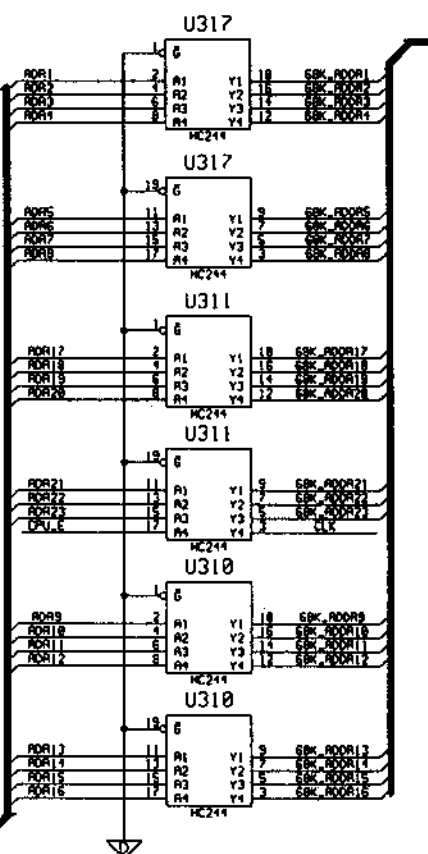
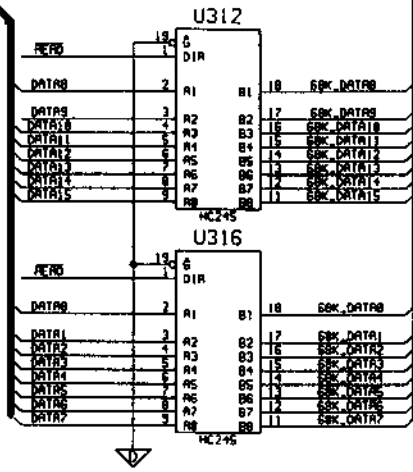

LCR-817/819

| | | | | |
|---|---|--|-------------|--------------|
| DRAWN BY  | CHECKED BY  | APPROVED BY  | MODEL NO | LCR-METER |
| | | | DESCRIPTION | CPU BOARD |
| | | | DRAWING NO | CR01S010 1/5 |

A

B

C

D

1

FROM SWITCHING POWER

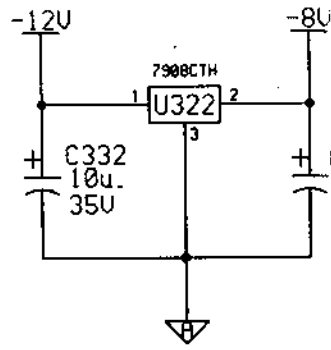
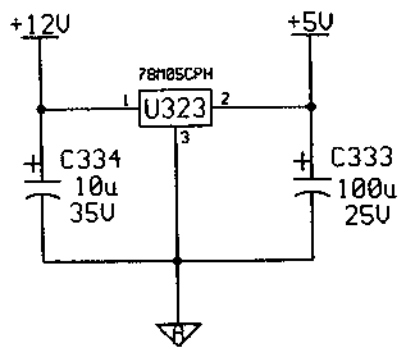
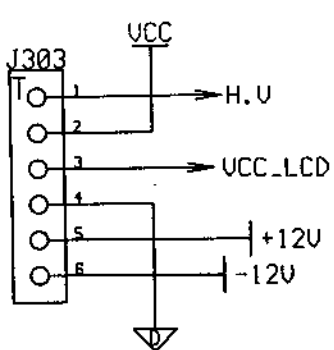

2

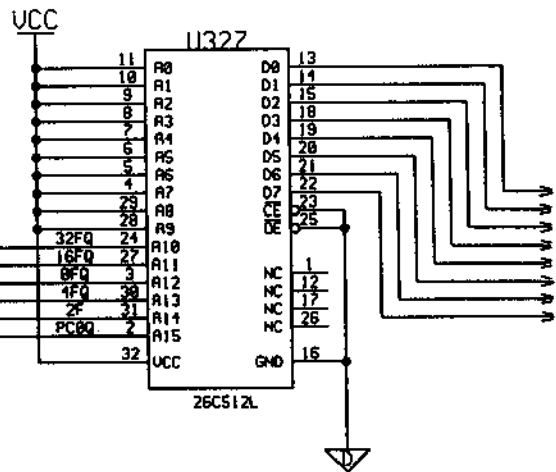

3

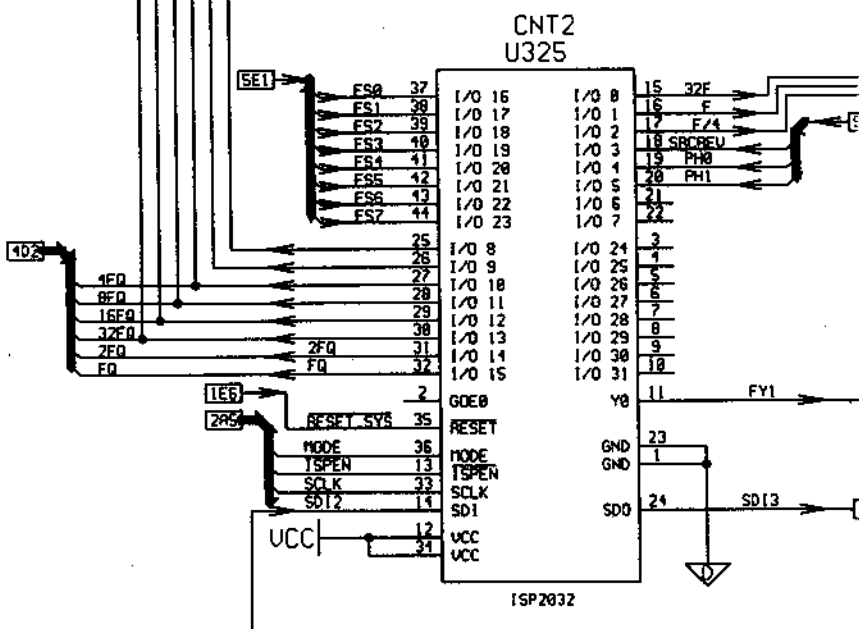

4

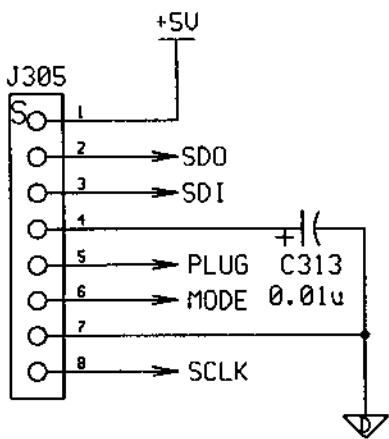

5

INDICATES SHEET NUMBER
 INDICATES VERTICAL ZONE NUMBER
 INDICATES HORIZONTAL ZONE NUMBER

1 F 6

E

F

G

H

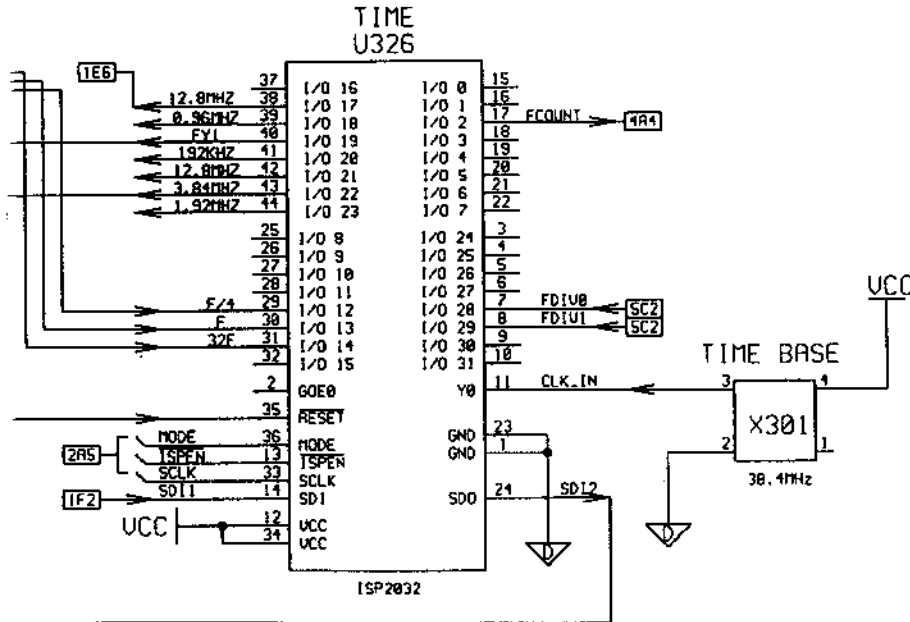
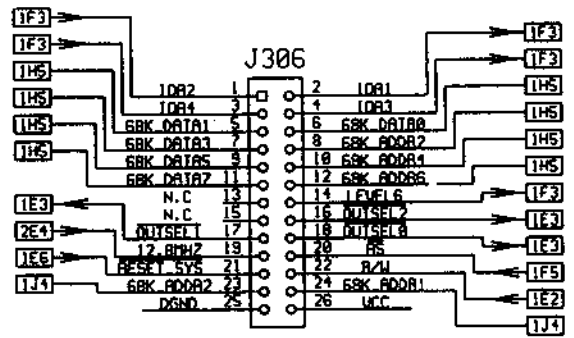
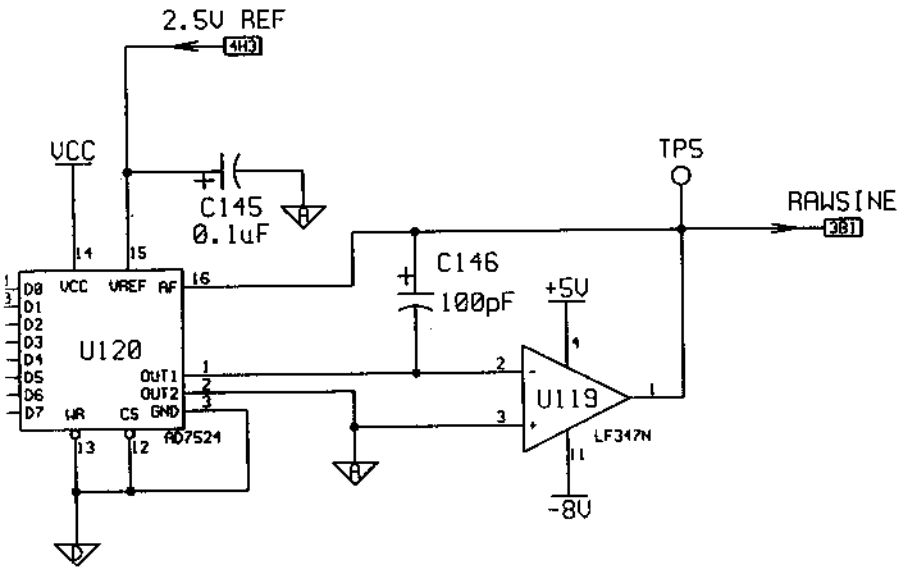

LOR-817/819

DRAWN BY



CHECKED BY



APPROVED BY



MODEL NO

DESCRIPTION

DRAWING NO

LCR METER

CPU BOARD

CR01S010 2/5

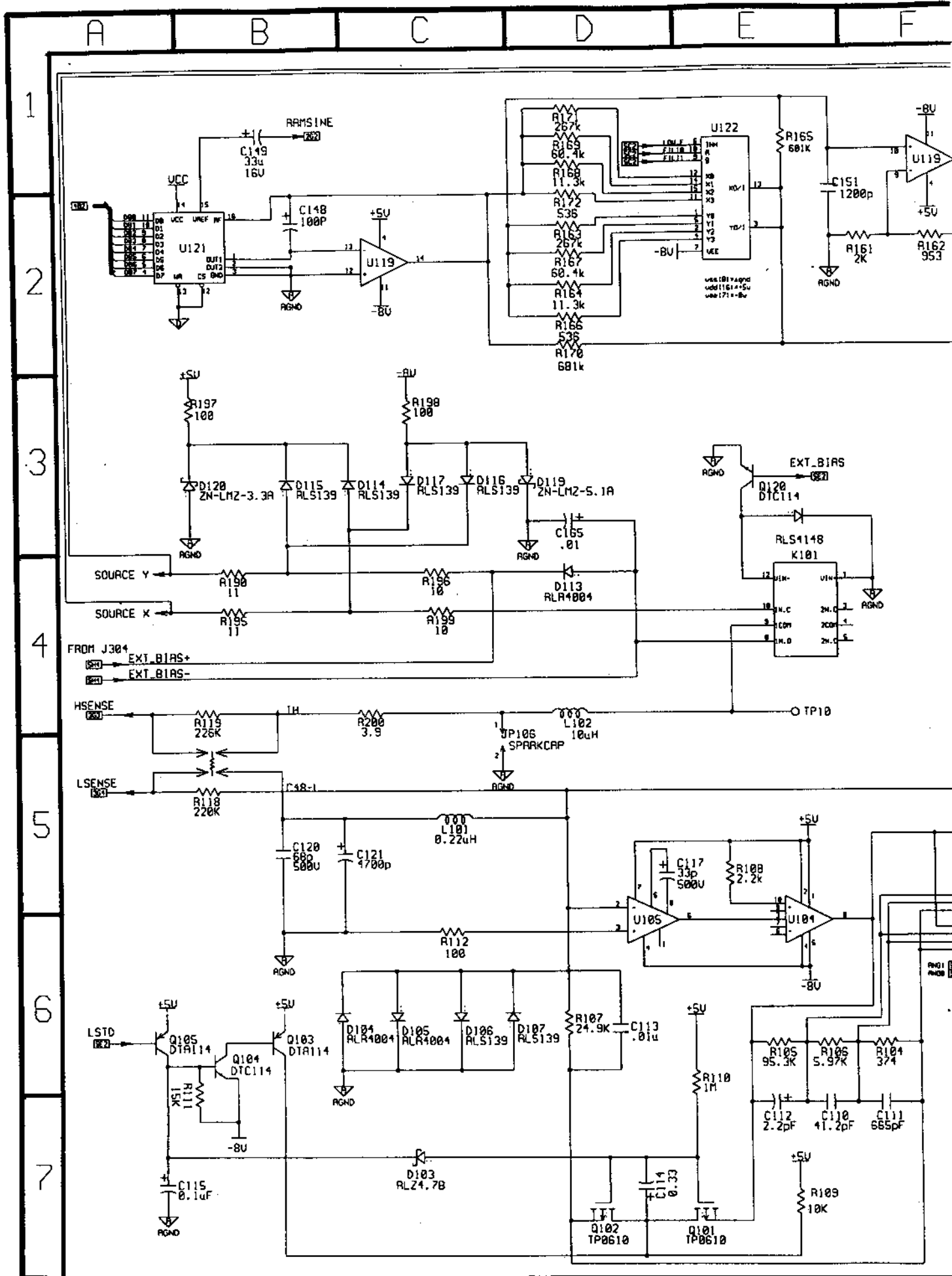

INDICATES SHEET NUMBER
 INDICATES VERTICAL ZONE NUMBER
 INDICATES HORIZONTAL ZONE NUMBER

1 F 6

G

H

I

J

K

L

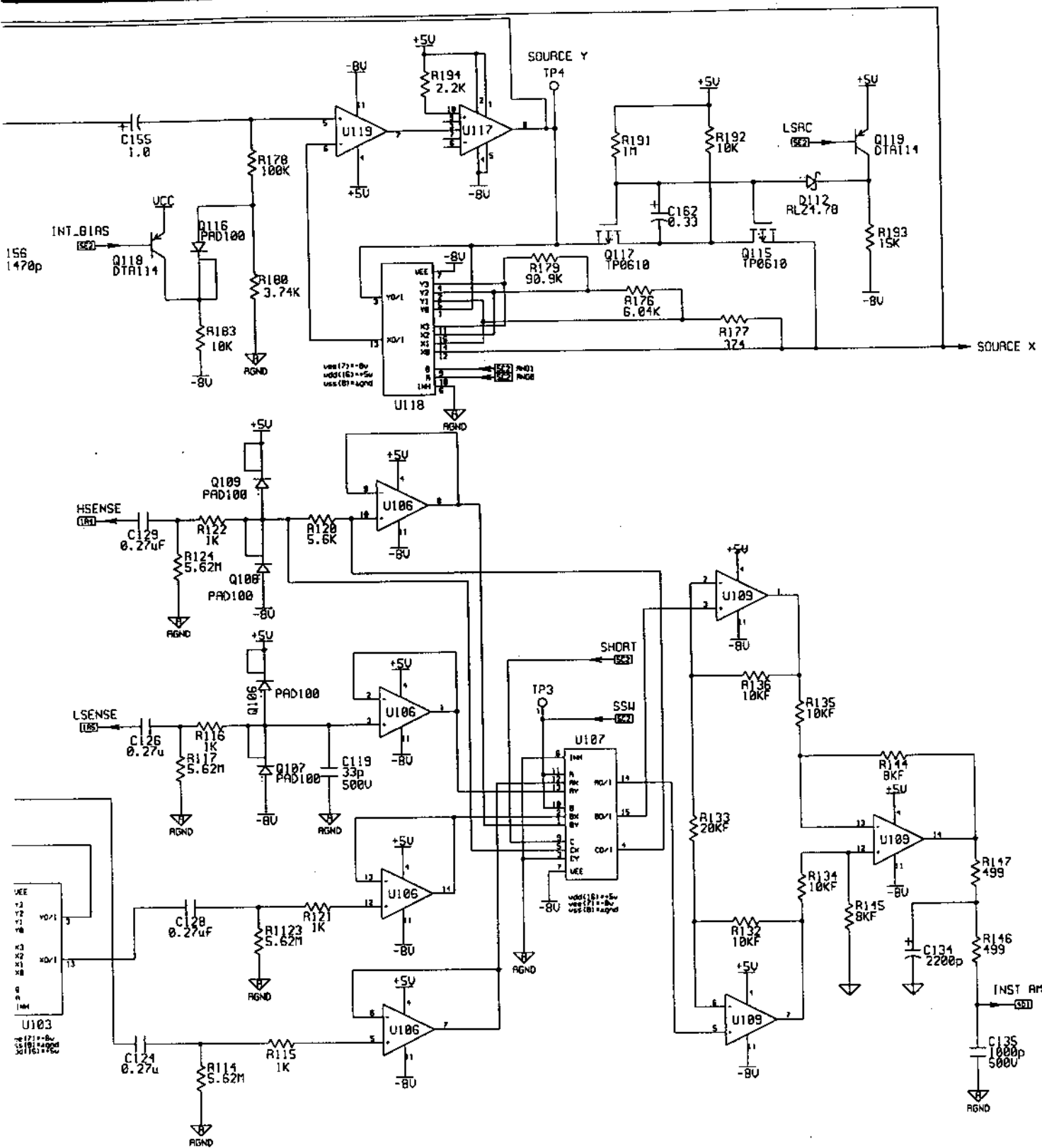

LCR-817/819

DRAWN BY

CHECKED BY

APPROVED BY

MODEL NO

LCR METER

呂
88.11.18
玉華

呂
88.11.18
玉華

呂
88.11.18
亞仁

DESCRIPTION

CPU BOARD

DRAWING NO

CR01S010 3/5

A B C D

1

2

3

4

5

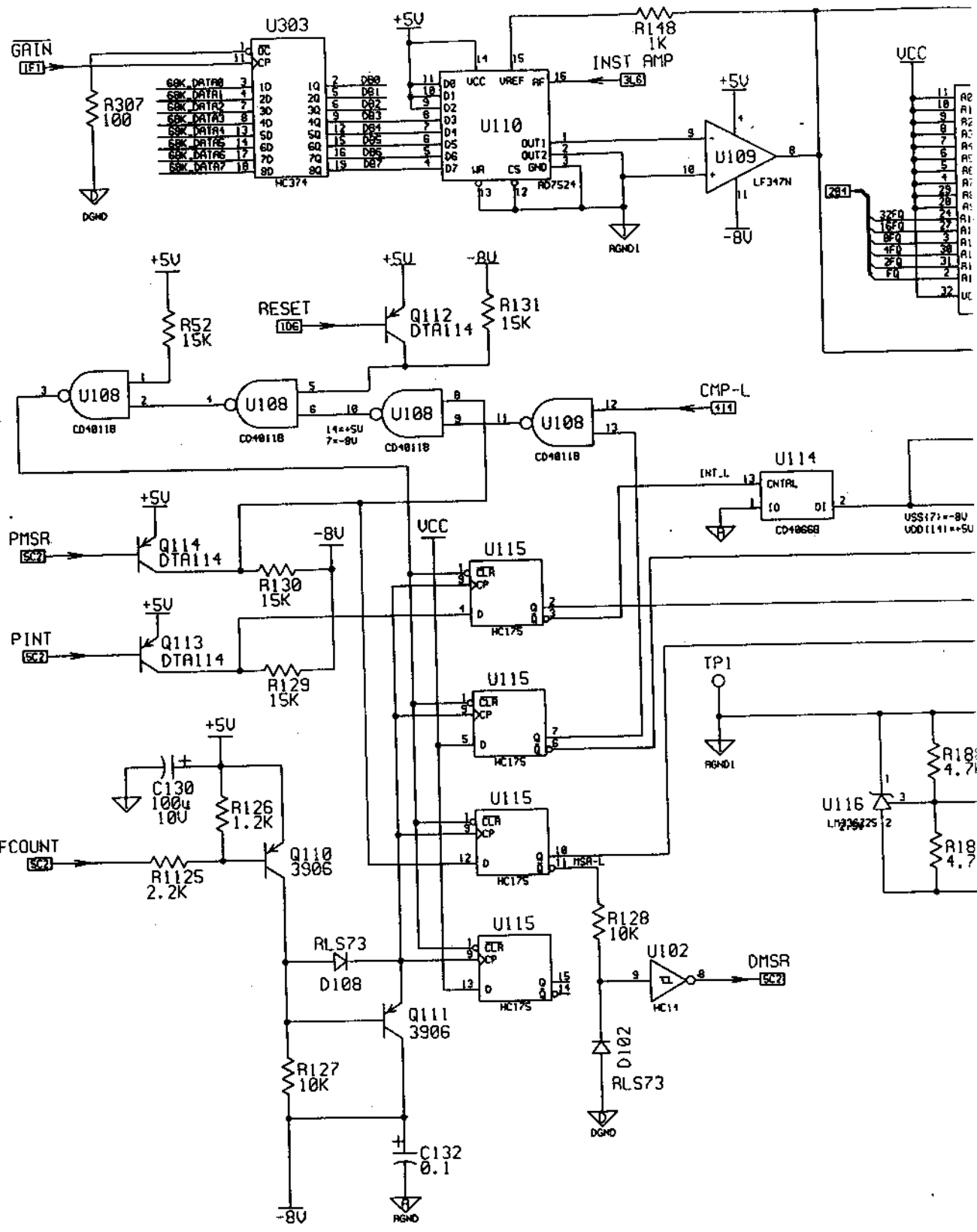

INDICATES SHEET NUMBER
 INDICATES VERTICAL ZONE NUMBER
 INDICATES HORIZONTAL ZONE NUMBER

1 F 6

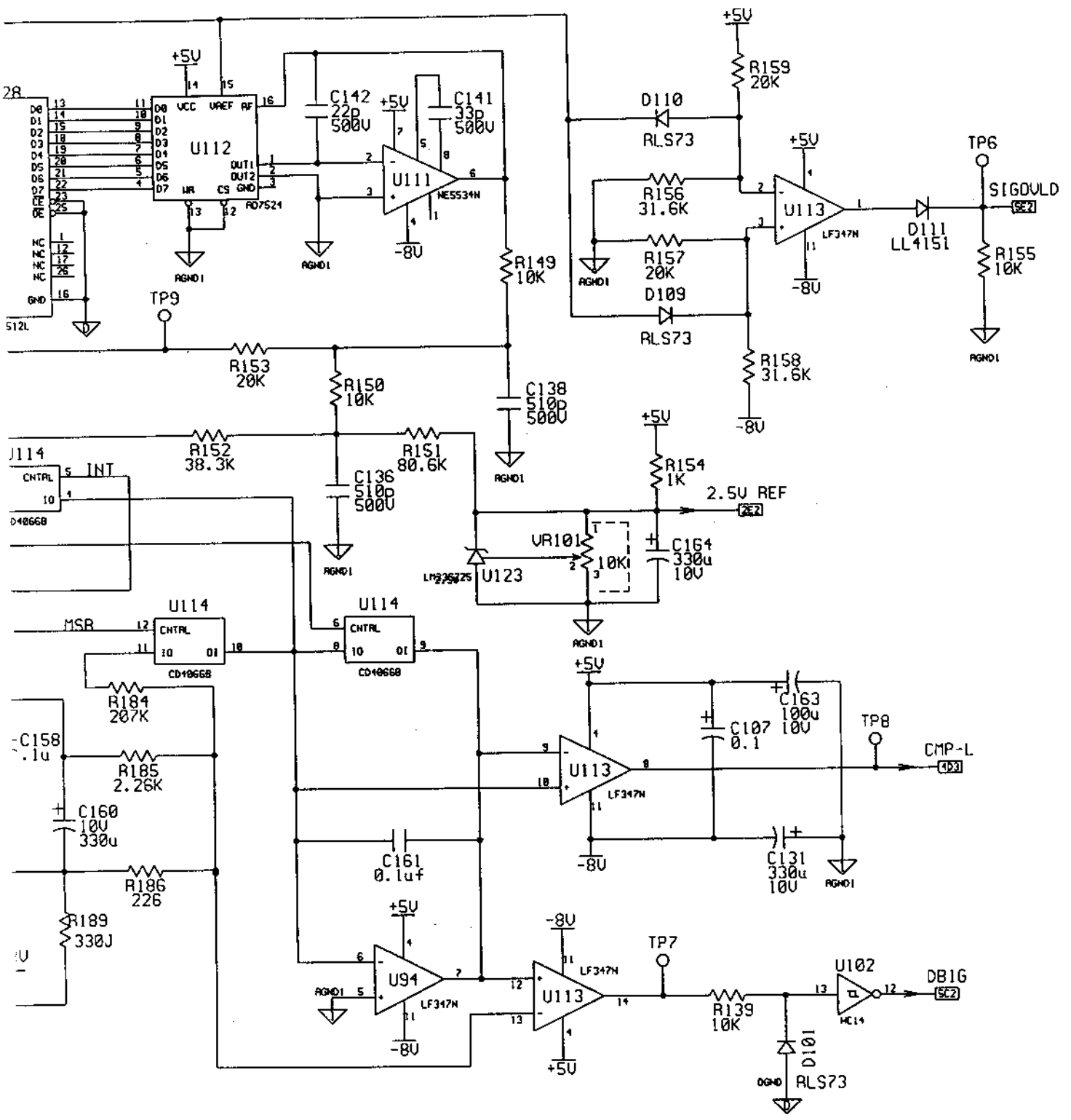

LCR-817/819

| | | | | |
|---------------------------------|-----------------------------------|------------------------------------|-------------|--------------|
| DRAWN BY 呂 88.11.18 玉華 | CHECKED BY 呂 88.11.19 玉華 | APPROVED BY 張 88.11.18 張仁 | MODEL NO | LCR METER |
| | | | DESCRIPTION | CPU BOARD |
| | | | DRAWING NO | CR01S010 4/5 |

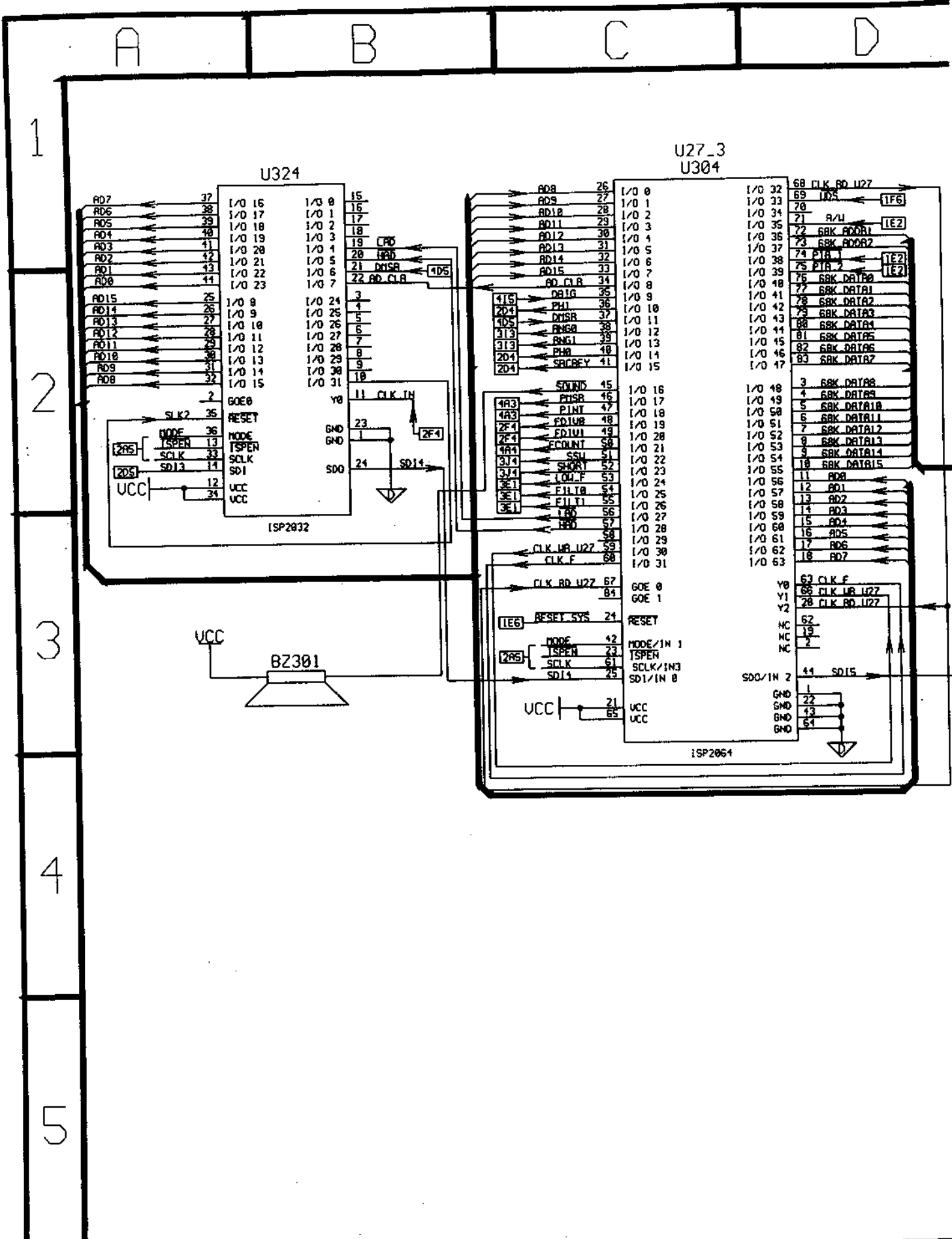

INDICATES SHEET NUMBER
 INDICATES VERTICAL ZONE NUMBER
 INDICATES HORIZONTAL ZONE NUMBER

1 F 6

E

F

G

H

FOR LCD BACKLIGHT

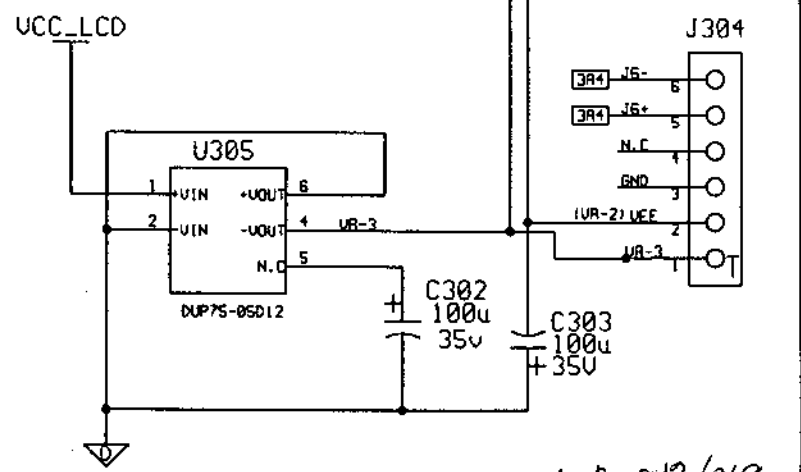
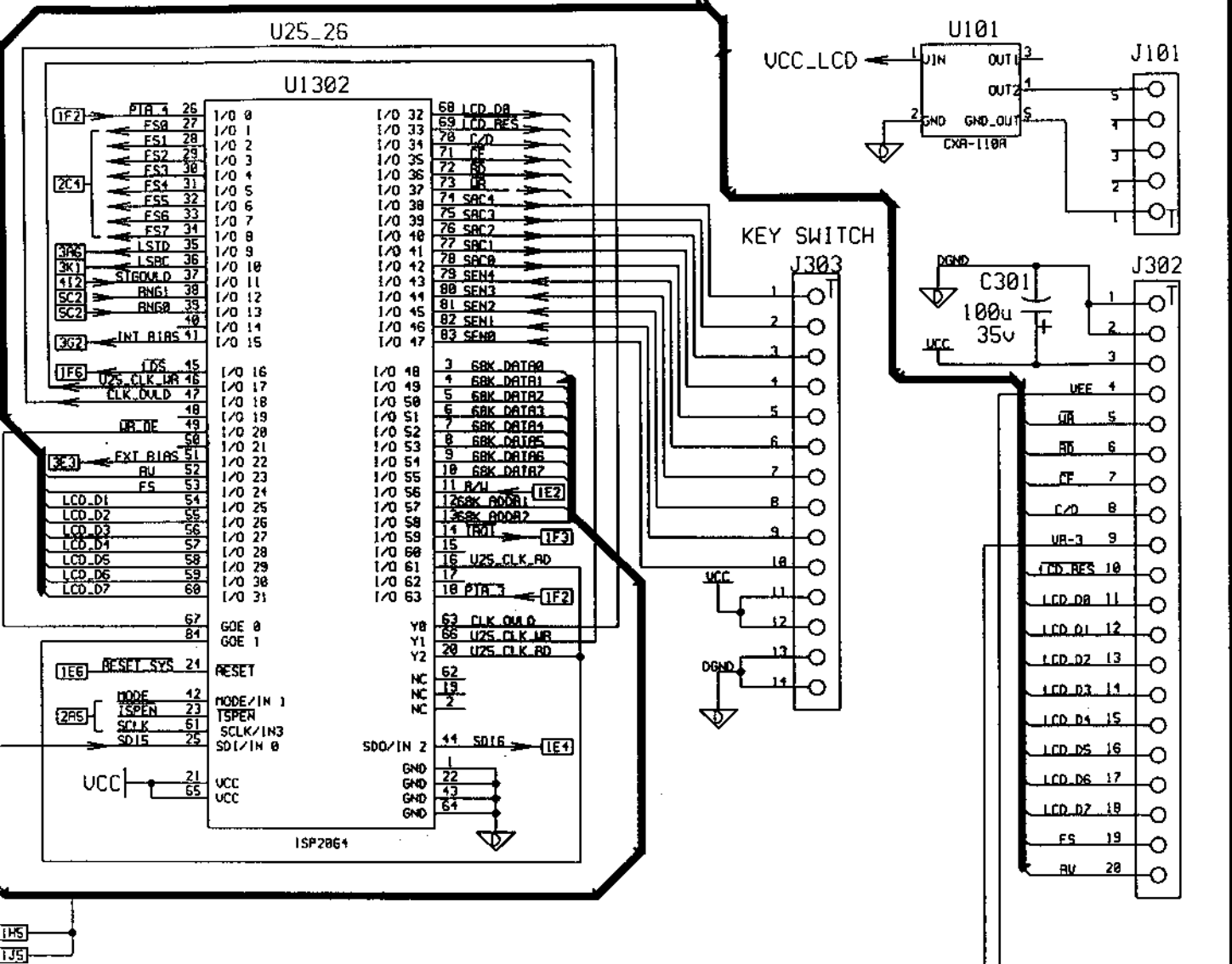

LOR-817/819

| | | | | |
|---|---|--|-------------|--------------|
| DRAWN BY  | CHECKED BY  | APPROVED BY  | MODEL NO | LCR METER |
| | | | DESCRIPTION | CPU BOARD |
| | | | DRAWING NO | CR01S010 5/5 |

CR01P020-1

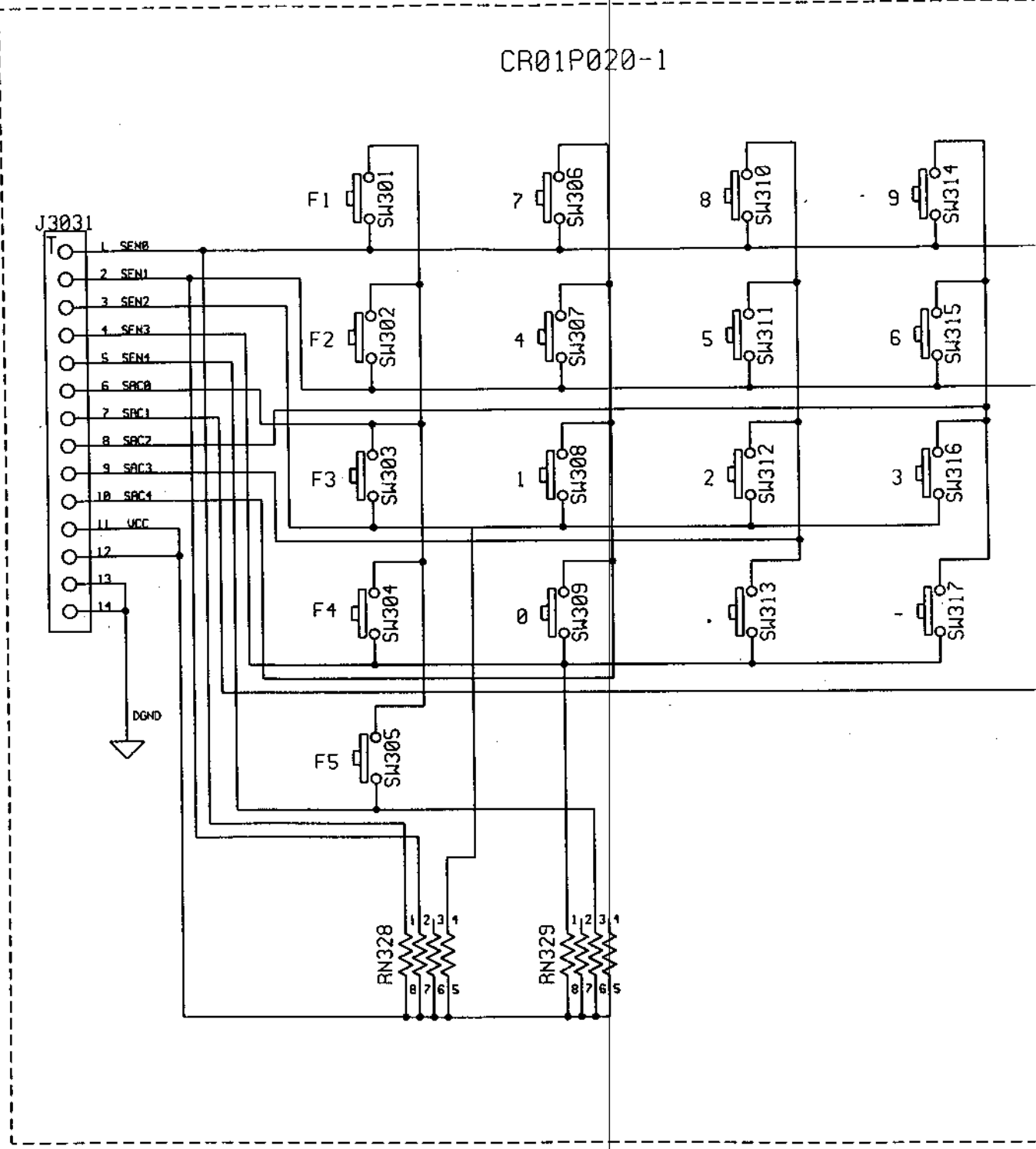

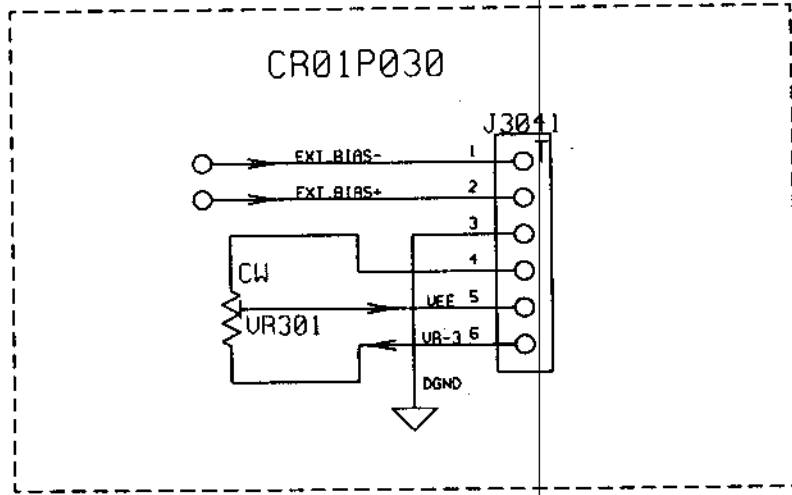
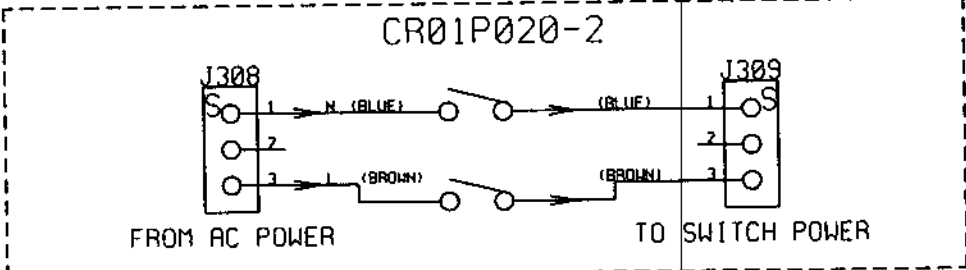
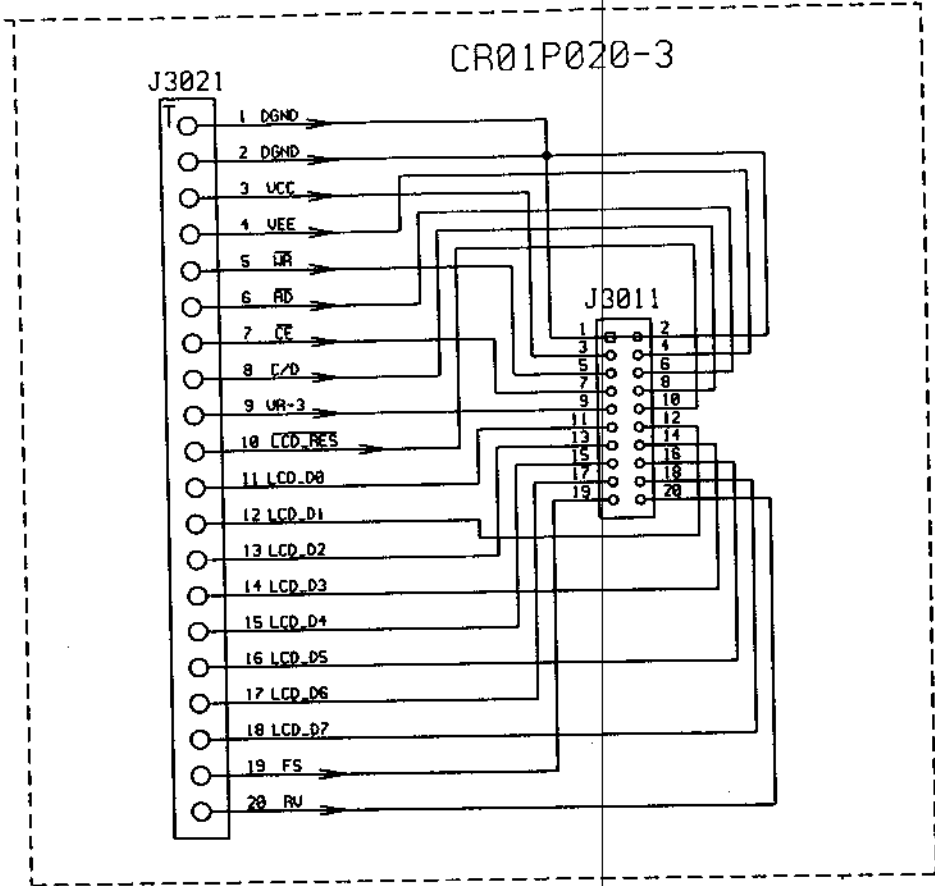
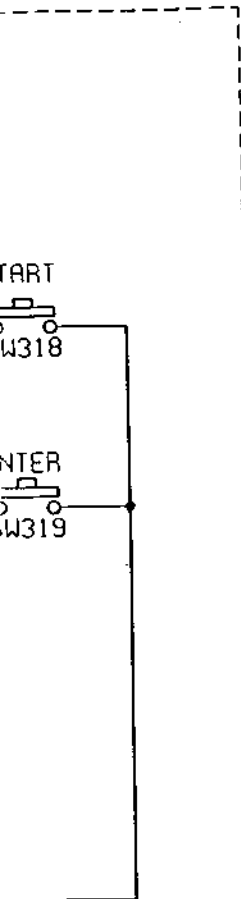

LCR-817/819

| | | | | |
|---------------------------------|-----------------------------------|------------------------------------|-------------|--------------|
| DRAWN BY 呂 88.11.18 玉華 | CHECKED BY 呂 88.11.18 玉華 | APPROVED BY 呂 88.11.18 亞仁 | MODEL NO | LCR METER |
| | | | DESCRIPTION | KEY/DISPLAY |
| | | | DRAWING NO | CR01S020,030 |